

# ***DELTA WASP 3MT***



***INDUSTRIAL  
LINE 4.0***



# DELTA WASP 3MT INDUSTRIAL 4.0

Con un'area di stampa chiusa di grandi dimensioni e la versatilità che la contraddistingue, la stampante 3D Delta WASP 3MT INDUSTRIAL definisce un nuovo standard nel mondo della manifattura additiva.

*With a closed build area of big dimension and its unique versatility, 3D printer Delta WASP 3MT INDUSTRIAL defines a new standard in the world of additive manufacturing.*

La Delta WASP 3MT INDUSTRIAL 4.0 è la stampante 3D ottimizzata per la stampa di grandi dimensioni.

*Delta WASP 3MT INDUSTRIAL 4.0 is the 3D printer optimized for big-size printing.*

## DESCRIZIONE PRODOTTO

Delta WASP 3MT INDUSTRIAL 4.0 è realizzata in metallo, con cinghie indeformabili caricate in acciaio, coibentata per l'isolamento termico e dei rumori.

Con questa stampante 3D per le grandi dimensioni è possibile realizzare pezzi con la precisione tipica delle stampanti più piccole grazie all'estrusore "SPITFIRE EXTRUDER" che lavora con il tradizionale filamento oppure realizzare pezzi grandi e robusti in tempi brevi con l'uso del "PELLET EXTRUDER" partendo direttamente dalla plastica in pellet industriale.

Delta WASP 3MT INDUSTRIAL 4.0 può essere connessa alla rete e quindi gestire la stampante direttamente tramite cellulare, tablet o computer.

All'interno della stampante è stata inserita una fotocamera per monitorare la stampa anche se situati altrove.

## PRODUCT DESCRIPTION

*Delta WASP 3MT INDUSTRIAL is manufactured in metal with strong steel cored belts and features a thermal and acoustic insulation.*

*With this big dimension 3D printer is possible to create pieces with the high resolution typical of smaller printers thanks to "SPITFIRE EXTRUDER" which works with the standard filament or creating big and strong prints quickly with "PELLET EXTRUDER" by using directly industrial plastic compounds.*

*Delta WASP 3MT INDUSTRIAL 4.0 can be connected to Wi-fi network so that you can manage your printer from smartphone, tablet or PC.*

*Inside the printer there's now a camera for monitoring the print even from remote.*

# DETTAGLI TECNICI

## INFORMAZIONI DI STAMPA 3D

Massimo volume di stampa: Ø1000 x h 1000 mm  
(h max 1200 mm)

Altezza minima del layer filamento: 100 micron

Altezza minima del layer pellet: 500 micron

Pellet utilizzato: Ø da 2 a 6 mm

Filamento utilizzato: Ø 1.75 mm

Massima velocità di stampa(\*): 200 mm/s

Massima velocità di spostamento(\*): 400 mm/s

Accelerazione(\*): 150 mm/s<sup>2</sup>

Piano di stampa: riscaldato fino a 110 C°

\* Tutti i dati relativi alle velocità si riferiscono alla  
Delta WASP 3MT industrial 4.0 con estrusore Spitfire

## MATERIALI

Materiali utilizzabili

Filament Ø1.75 con "SPITFIRE EXTRUDER"

Pellet: Ø 2-6 con "PELLET EXTRUDER"

PLA

ABS

PETG

TPU

POLYPROPYLENE

PA

## TOOL CONFIGURABILI

SPITFIRE EXTRUDER:

estrusore per stampe precise e di alta qualità

Diametro ugello: 1.2 mm

(filamento diametro 1.75 mm)

PELLET EXTRUDER:

estrusore per stampe grandi e veloci

Diametro ugello: 3 mm (diametro pellet 2-6 mm)

## SOFTWARE

Sistemi operativi: Windows, Mac, Linux

Software di slicing: compatibile con tutti i software  
di slicing (Cura – SLic3r – Simplify3D®)

Tipo di file: .stl, .obj, .gcode

## INTERFACCIA

Pendrivel USB

Wifi network

Schermo TFT touch

# TECHNICAL DETAILS

## INFORMATION ON 3D PRINTING

Build volume: Ø1000 x h 1000 mm (h max 1200 mm)

Minimum layer height filament: 100 micron

Minimum layer height pellet: 500 micron

Pellet used: Ø from 2 to 6 mm

Filament used: Ø 1.75 mm

Print speed max(\*): 200 mm/s

Travel speed max(\*): 400 mm/s

Acceleration(\*): 150 mm/s<sup>2</sup>

Bed temperature max: 110 C°

\* All data relative to speed make reference to a  
Delta WASP 3MT Industrial 4.0 with Spitfire extruder

## MATERIALS

Suitable materials

Filament Ø1.75 with "SPITFIRE EXTRUDER"

Pellet: Ø 2-6 with "PELLET EXTRUDER"

PLA

ABS

PETG

TPU

POLYPROPYLENE

PA

## SUITABLE TOOLS

SPITFIRE EXTRUDER:

extruder for precise and high-quality prints

Nozzle diameter: 1.2 mm

(filament diameter 1.75 mm)

PELLET EXTRUDER: extruder for big and fast prints

Nozzle diameter: 3 mm (pellet diameter 2-6 mm)

## SOFTWARE

Operative system: Windows, Mac, Linux

Slicing software: compatible with all slicing softwares  
(Cura – SLic3r – Simplify3D®)

File type: .stl, .obj, .gcode

## INTERFACE

Pendrivel USB

Wifi network

Display TFT touch

## DIMENSIONI FISICHE

Dimensioni: 215 cm x 235 cm x 305 cm  
Peso macchina: 250 kg  
La macchina viaggia smontata e viene assemblata nell'ambiente di lavoro

## ALIMENTAZIONE

Input: 220/240 V 50/60 Hz  
Potenza assorbita:  
- Estrusore Pellet: 660W max  
- Estrusore Spitfire: 130W max  
- Piano Riscaldato: picco 1,6 Kw / medio 150 W  
- Drivers: picco 200 W

## TEMPERATURA

Ambiente d'utilizzo: 20-30° C  
Magazzino: 0-30° C

## MECCANICA

Telaio e copertura:  
alluminio, acciaio verniciato, policarbonato, PU.  
Carterature in metallo, azzera le vibrazioni della macchina, garantisce maggiore precisione di stampa.

Piano di stampa:  
Alluminio rettificato

Movimenti:  
ruote di nylon su profili in alluminio anodizzato  
cinghie in delrin con anima in acciaio inox resistenti alle alte temperature

Isolamento:  
schiuma in materiale isolante termo-acustico

Motori:  
Stepper

## INNOVAZIONI TECNICHE

WIFI:

macchina in rete monitorare e controllare la macchina

Nuova GUI:  
interfaccia rinnovata tattile con display TFT

Camera on-board:  
per il monitoraggio e timelapse

Assistenza remota:  
consente ai tecnici WASP possono seguirti passo a passo anche a distanza

## PHYSICAL DIMENSION

Dimensions: 215 cm x 235 cm x 305 cm  
Machine weight: 250 kg  
The machine travels disassembled and it's assembled in the work space

## POWER SUPPLY

Input: 220/240 V 50/60 Hz  
Power rating:  
- Pellet extruder: 660W max  
- Spitfire extruder: 130W max  
- Hot pad: max 1,6 Kw / mid 150 W  
- Drivers: max 200 W

## TEMPERATURE

Use: 20-30° C  
Warehouse: 0-30° C

## MECHANICS

Frame and cover:  
aluminum, painted steel, polycarbonate, PU.  
metal carters, defeats machine's vibrations, allows a more precise machine

Bed:  
rectified aluminum

Movements:  
nylon wheels on anodized aluminum sliders  
steel cored belts in delrin resistant to high temperature

Insulation:  
expanded polymer for thermal and acoustic insulation

Motors:  
Stepper

## TECHNICAL INNOVATION

WIFI:

machine connected to the network for monitoring and control

New GUI:  
new touch interface with bigger TFT display

Camera on-board:  
for monitoring and timelapse

Remote intervention:  
WASP technicians can follow you step-by-step remotely

# INDUSTRIAL 4.0 FEATURES

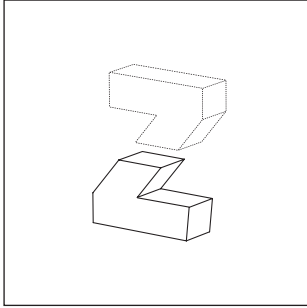

**FREE-ZETA  
SYSTEM**

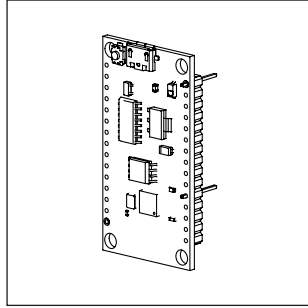

**NEW 32 BIT  
BOARD x4 POWER**

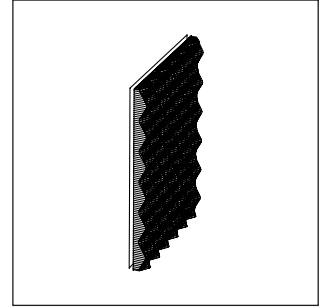

**CLOSED CHAMBER  
HEAT / NOISE**

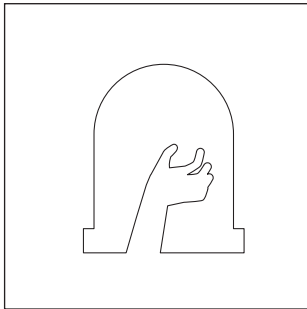

**RESURRECTION  
SYSTEM**

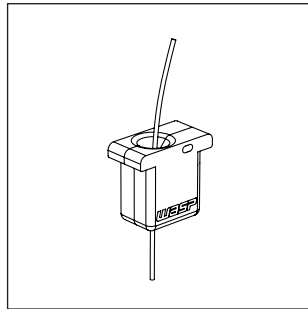

**END-MATERIAL  
SENSOR**

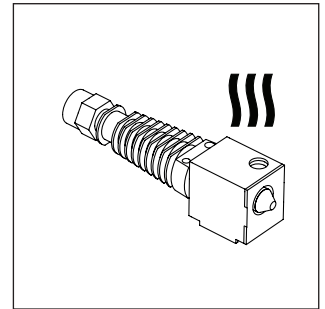

**HIGHER TEMPERATURE  
EXTRUSION**

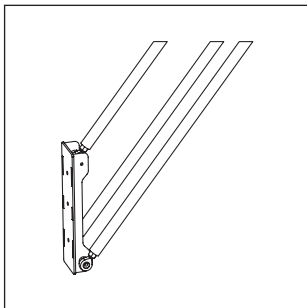

**THREE ARMS  
STABILIZATION**

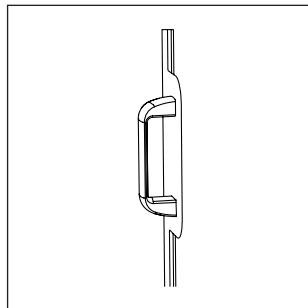

**OPEN DOOR  
SAFETY SENSOR**

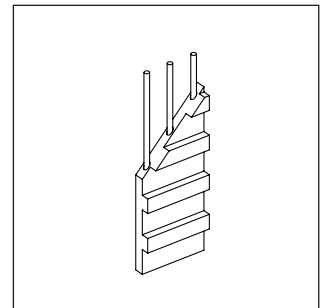

**STEEL CORED BELTS  
FOR HIGH TEMPER**

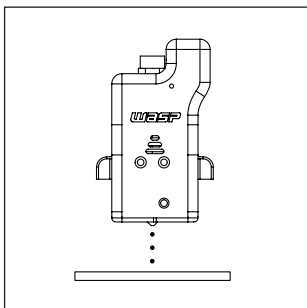

**SELF-CALIBRATION  
SYSTEM**

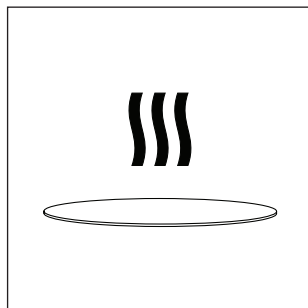

**HEATED BED  
UP TO 100°C**

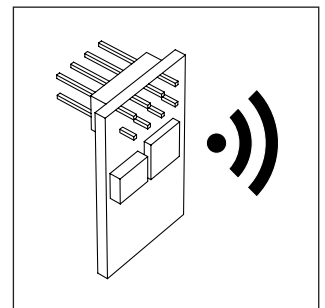

**WIFI MODULE FOR  
REMOTE CONTROL**

# **WORLD'S ADVANCED SAVING PROJECT**



**INFO**  
info@3dwasp.com

**Tel.**  
+39 0545 87858

**WEBSITE**  
www.3dwasp.com

**YOUTUBE**  
3D WASP

**TWITTER**  
3dwasp

**FACEBOOK**  
3dwasp

Totally developed and made in Italy  
CSP s.r.l. | Viale Zaganelli 26, Massa Lombarda 48024  
P.iva IT02108930393

